

---

## Chapter 2

### Positive and Negative Numbers

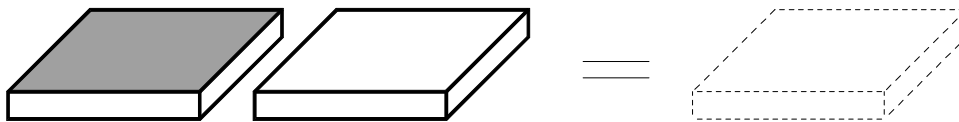
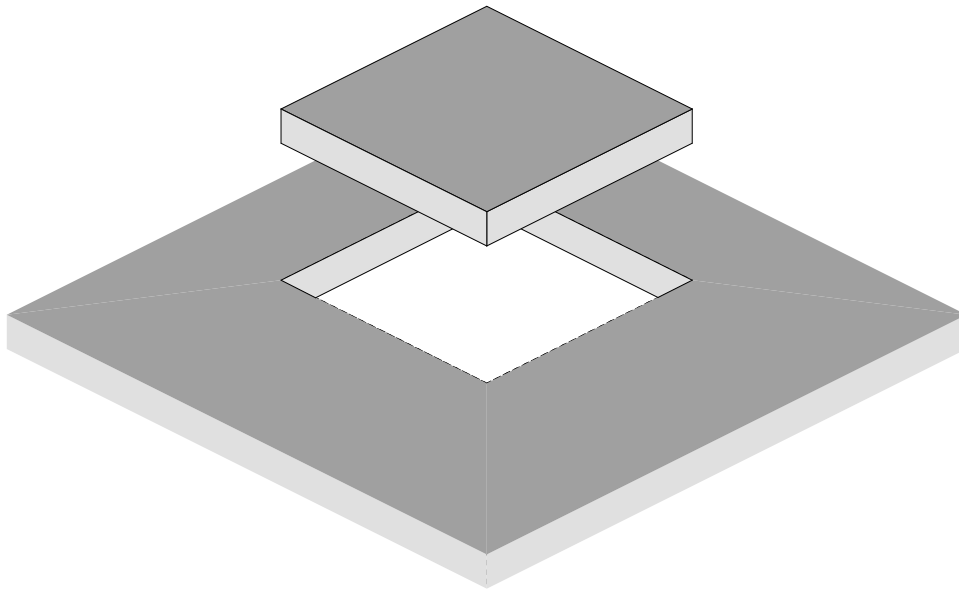

---

# Section 1

## Positive and Negative Numbers

---

### The Meaning of Positive and Negative Numbers

---

Imagine a slab with a square section removed:

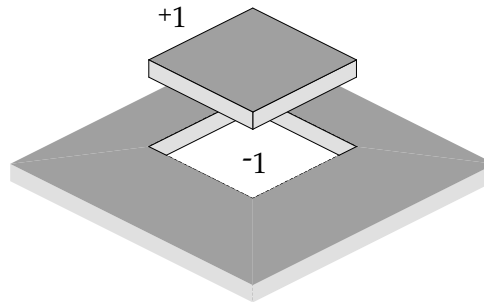

Positive one (+1) is the square chip that is cut out of the slab. Negative one (-1) is the hole that it came out of.

Add +1 and -1 back together and you fill in the hole; zero is your result:

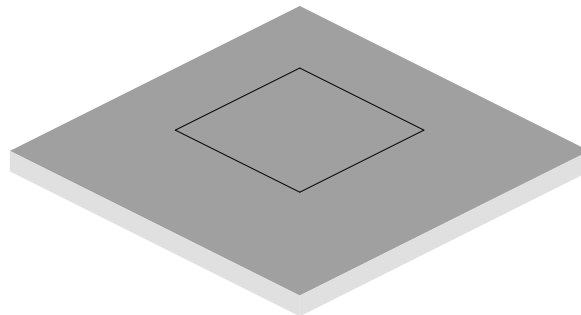

For practical purposes, it is more convenient to use two chips of different colors to represent +1 and -1. When they are added together, they cancel each other out, leaving zero.

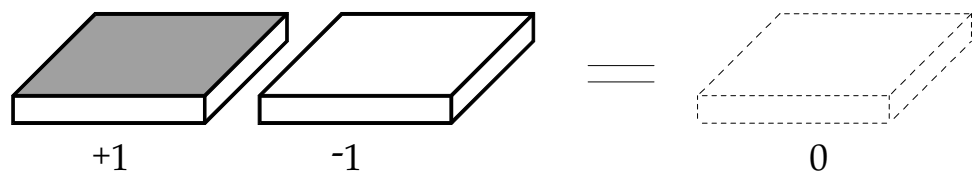

## Signed Numbers and Flip-Chips™

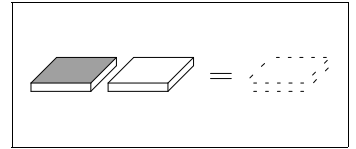

A number with a sign (+ or -) directly to its left (in front of the number when reading from left to right) is called a **signed number**. The positive (+) or negative (-) sign tells *what color* chips the number represents and the number tells *how many* of these chips are represented. Together, all of the positive and negative numbers are called **integers**.

With a piece of material which has a different color on each side it is possible to make a **Flip-Chip**—a piece which represents +1 with one side up, and -1 with the other side up. *Flipping the chip changes the sign!*

The chips we use are colored on one side and white on the other side, so we call the colored side **positive** or **plus** (+) and the white side **negative** or **minus** (-). This way we always know which side is which.

*Flipping the chip changes the sign!*

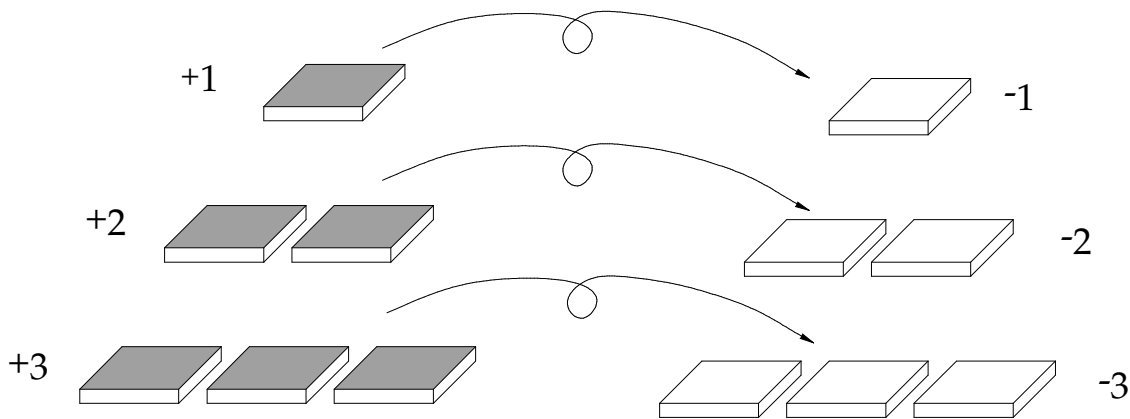

And a second negative sign flips the chip *again*!:

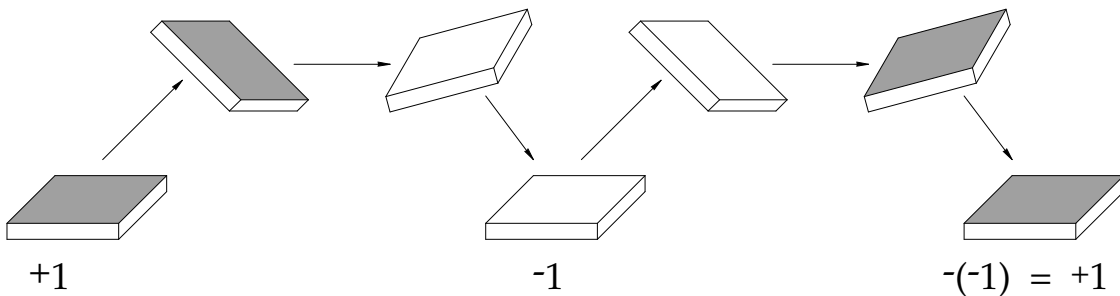

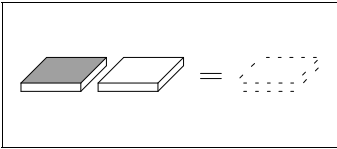

## Double or Multiple Signs

A number may be shown having more than one sign in front (to the left) of it. These signs can be written in several ways; parentheses are often used to enclose the number and one sign:

$$+(-3)$$

$$-(-2)$$

$$+(+5)$$

$$+(-4)$$

Thinking of these numbers as chips, remember that each negative (-) sign in front of a number flips the chips one time, so two minus signs flip the chips twice, giving a positive (+) side up. We always begin with the colored (+) side up before we start flipping. Here is the result of four different combinations of signs:

$$\begin{aligned} +(+3) &= +3 \\ +(-3) &= -3 \\ -(+3) &= -3 \\ -(-3) &= +3 \end{aligned}$$

Each negative sign means to flip the chips once; each positive sign means to leave them alone. We always start with the colored (positive) side up.

## Cancelling of Positives and Negatives

The basic principle of grouping positive and negative chips together is that one positive chip grouped with one negative chip cancels to give zero. This means that if we put an equal number of positive and negative chips together, they will cancel to give zero:

+4 cancels -4

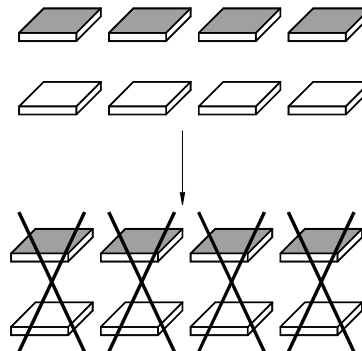

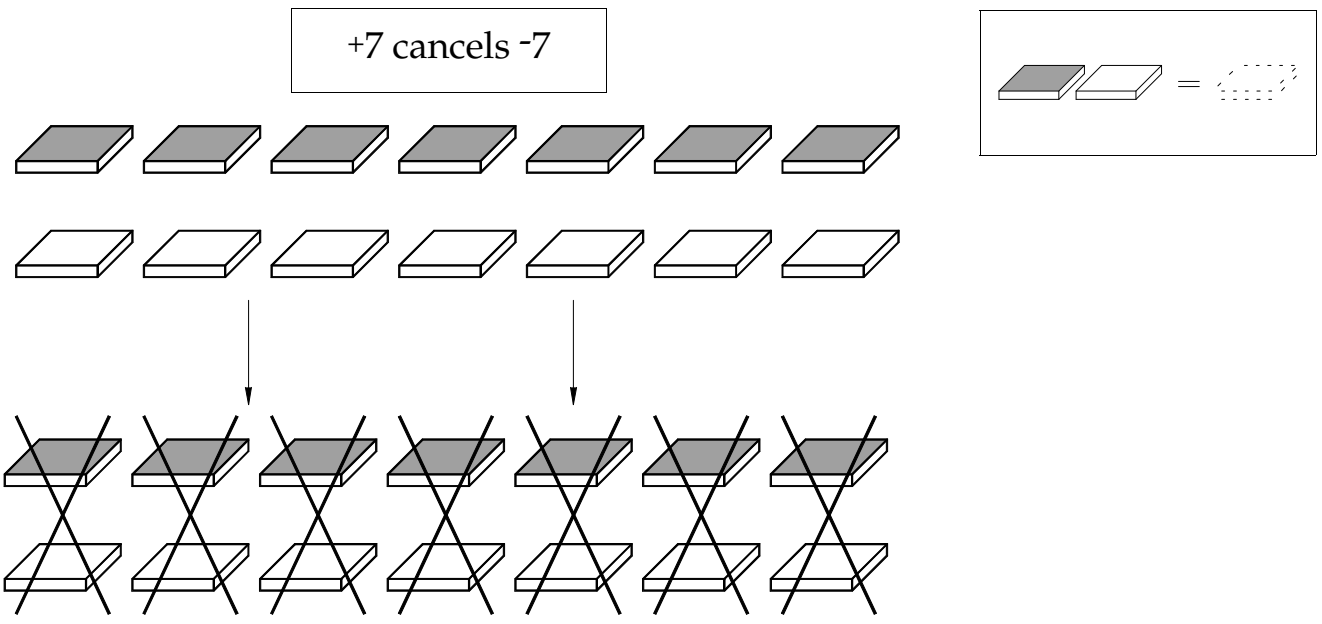



---

### Symbols and Signs

---

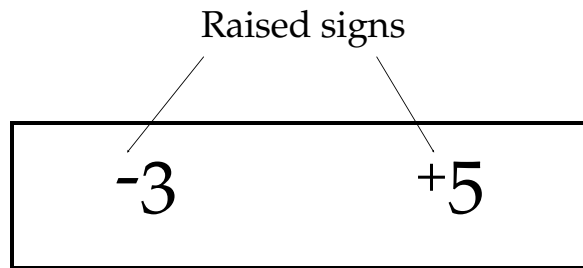
We have been using several symbols that may be unfamiliar. First we have been showing positive and negative numbers with small plus or minus signs that are on the left of the number and raised up slightly.



Positive numbers can be shown *with or without* the positive sign. The familiar number 4 and the new symbol +4 have the same meaning:

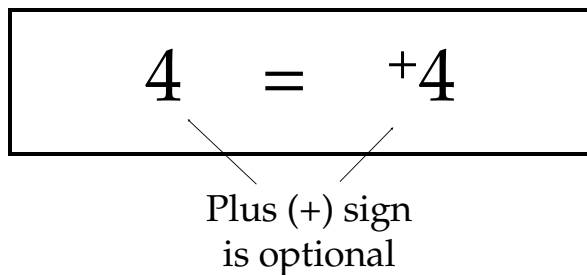

Although a positive sign is optional, a negative number must always be shown with a minus sign so that we can tell that it is negative.

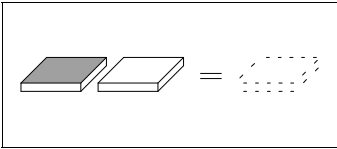

## Exercises

Use the chips to illustrate the following results:

Example: 5 and -5 cancel to 0

Solution:

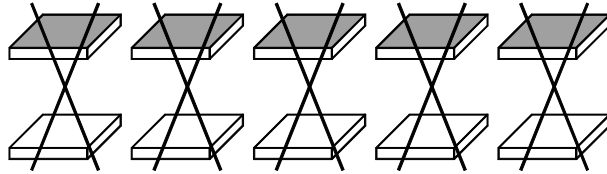

Example:  $-(-4) = +4$

Solution:

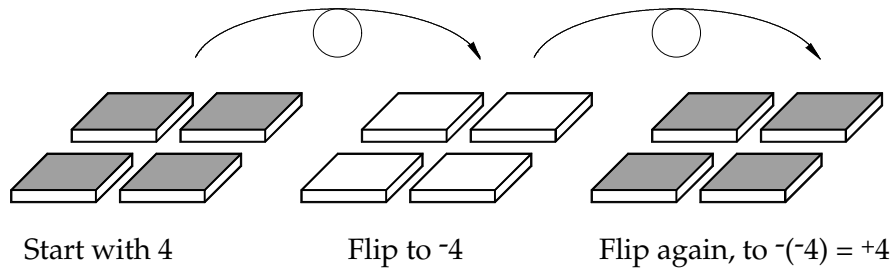

1.  $-(-7) = +7$
2.  $-(+3) = -3$
3.  $-(-11) =$
4.  $-(+3) =$
5.  $+(-9) =$
6.  $-(-10) =$
7.  $-(3) = -3$
8. 3 and -3 cancel to 0
9. 6 and -6 cancel to 0
10. -6 and  $-(-6)$  cancel to 0
11. -11 and +11 cancel to 0
12.  $-(-17) =$
13.  $+(-0) =$
14.  $-(-0) =$

---

## Section 2

### Addition of Signed Numbers

---

#### The Meaning of Addition

---

In the past, adding two numbers meant that we took two amounts and combined them. Now that we have invented positive and negative numbers, addition will still have the same basic meaning, as long as we understand the idea that equal groups of positive and negative chips cancel each other out.

#### Adding Two Positives

---

If we are adding two positive numbers, we simply combine two groups of positive chips to give one larger group of all positive chips:

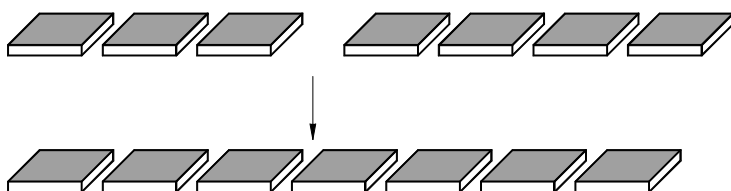

$$(+3) + (+4) = 7$$

#### Adding Negatives

---

To add negative numbers, we combine the groups of negative chips. For example:

$$(-2) + (-5)$$

This expression means that we should take 2 negative chips and 5 negative chips and group them together. The result is clearly 7 negative chips:

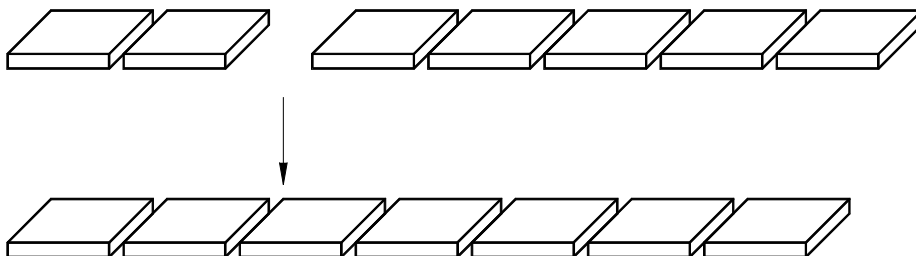

$$(-2) + (-5) = -7$$

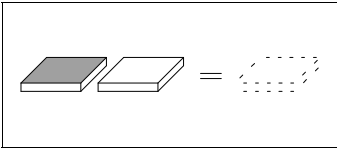

As we can see from the last two examples, adding numbers with the same sign is very easy—we simply combine the chips and count the total number:

$$(+6) + (+3) = +9$$

$$(+12) + (+3) = +15$$

$$(-3) + (-5) = -8$$

$$(-6) + (-4) = -10$$

The parentheses shown above are not required but can be helpful. We use them to separate the number from the addition sign; if you leave them out, make sure to keep the negative signs raised and close to the numbers:

$$-6 + -4 = -10$$

---

### Adding Negative and Positive Numbers

---

If we need to add a negative number and a positive number, we combine the two groups of chips and cancel out pairs of negatives and positives:

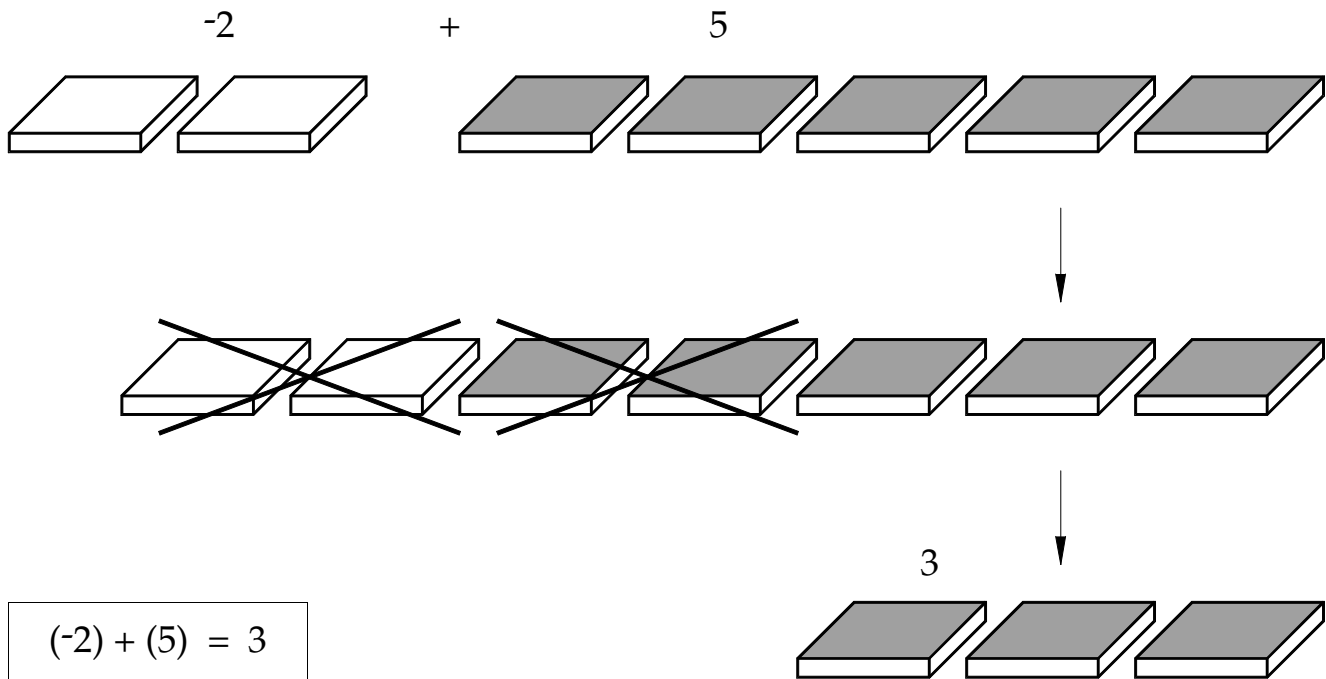

Did you notice that there were more positives than negatives? Because of this, when the cancelling is done, we are left with positives.



Here is an example of adding a positive number and a negative number where there are more negative chips:

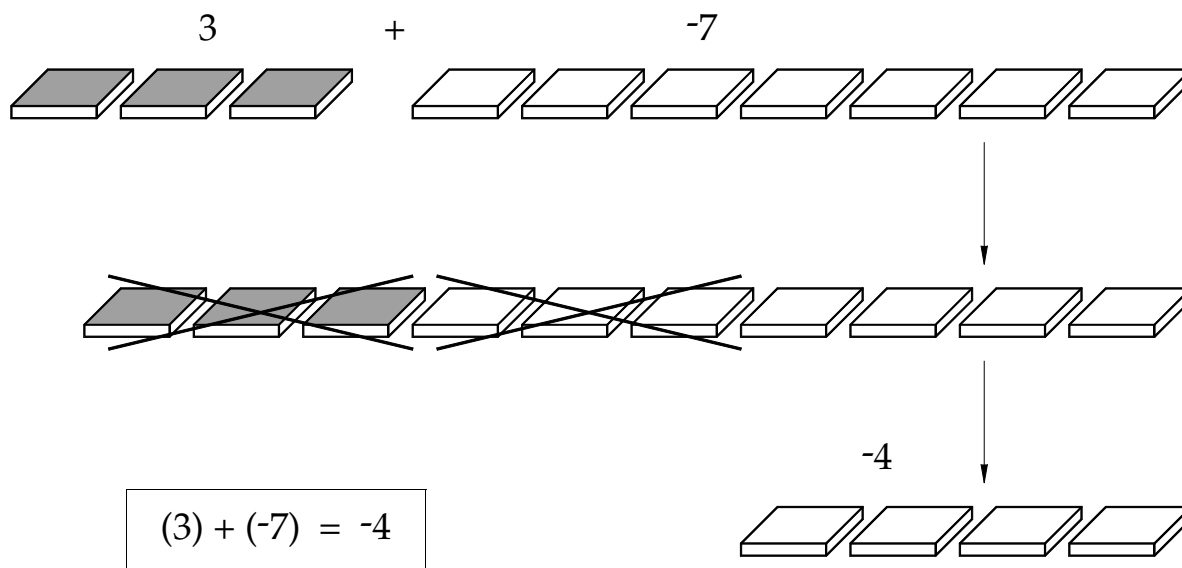
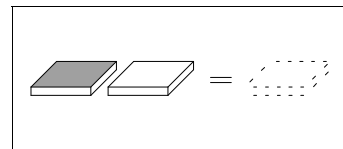

As you would expect, the positive chips cancelled out some of the negatives, but there are still negatives remaining.

---

## Summary

---

To add two numbers, we combine the chips, cancelling if we have a mixed group of positives and negatives:

- **Adding two positives**—Combine the groups of chips for a total of more positives.
- **Adding two negatives**—Combine the groups of chips for a total of more negatives.
- **Adding a positive and a negative**—Combine the groups of chips and let positive and negative chips cancel out in pairs. The chips which remain will have the same color (sign) as the larger original group.

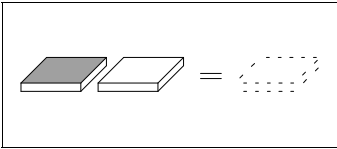

## Exercises

---

Use your chips to set up and solve the following addition problems:

1.  $(-5) + (+5) =$
2.  $(+3) + (+11) =$
3.  $(-5) + (-1) =$
4.  $(-3) + (-3) =$
5.  $(-1) + (-1) =$
6.  $(+8) + (+4) =$
7.  $(-4) + (-3) =$
8.  $(-3) + (-4) =$
9.  $(-6) + (-7) =$
10.  $(-12) + (-1) =$
11.  $(-7) + (+6) =$
12.  $(+7) + (-6) =$
13.  $(-11) + (+2) =$
14.  $11 + (-2) =$
15.  $4 + -5 =$
16.  $-4 + 5 =$
17.  $1 + (-2) =$
18.  $-1 + (-3) =$
19.  $-1 + 3 =$
20.  $-2 + -3 =$
21.  $7 + -5 =$
22.  $-3 + -5 =$
23.  $-3 + 5 =$
24.  $6 + 2 =$
25.  $6 + (-2) =$
26.  $-6 + 2 =$
27.  $-6 + (-2) =$
28.  $4 + 5 =$
29.  $4 + -5 =$
30.  $-4 + 5 =$

---

## Section 3

### Subtraction of Signed Numbers

---

#### The Meaning of Subtraction

---

We were able to easily extend our old idea of addition to cover signed numbers, but we will have to do a little more work to invent a new definition of subtraction. By subtraction, we have always meant the concept of taking away part of what we have. For example:

$$7 - 3$$

With the chips, this means that we start with 7 chips and then take away 3 chips. The result is 4:

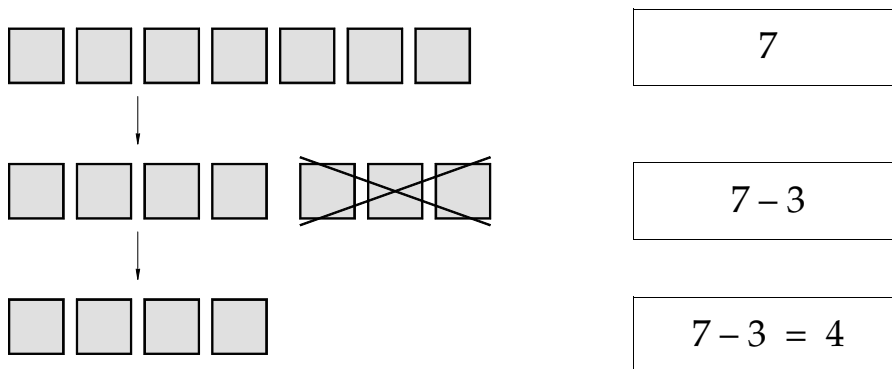

This standard idea of subtraction will also work well with the following example:

$$(-7) - (-3)$$

We start with 7 negative chips and take away 3 negative chips:

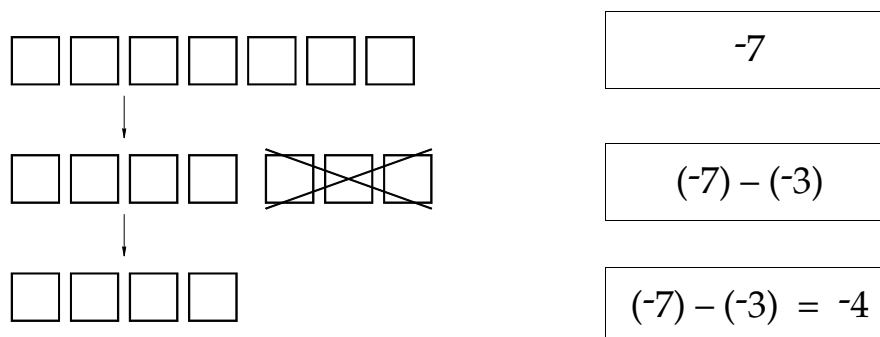

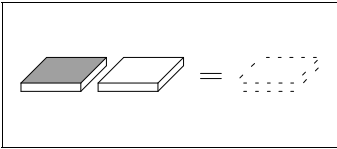

Although these examples work well with our idea of “taking away,” subtraction is not always that easy. What if we are asked to subtract more chips than we start with?

$$5 - 7$$

$$3 - 18$$

$$9 - 10$$

$$(-5) - (-6)$$

$$(-2) - (-8)$$

Our system of subtraction needs to make sense when given these types of problems. We also need to know what to do if we start with one color chips, but we are asked to take away or subtract the *other* color of chips:

$$3 - (-2)$$

$$-4 - 5$$

$$0 - (-6)$$

The old idea of “take away” is clearly not going to work for subtraction of signed numbers.

---

### Subtraction of Signed Numbers: Method I

---

Our first new method of doing subtraction will be very simple—in a given expression, each number will tell us how many chips are in one group, and the sign in front (to the left) of each number will tell us what color chips are in that group. We will then add the groups together. If the chips are different colors, let them cancel in pairs.

$$3 - 4$$

+3 (3 colored chips)

-4 (4 white chips)

Instead of subtraction, we think of the problem as adding groups of chips which are sometimes different colors. Look at each number and the sign to its left. Since 3 has no sign, it is positive; since 4 has a minus sign (–) it is negative. In this situation, *the subtraction sign is considered to be the same as a negative sign.*

When we add 3 and -4, the result is -1:

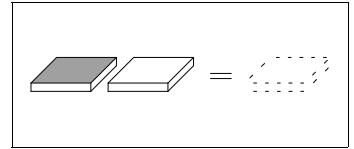
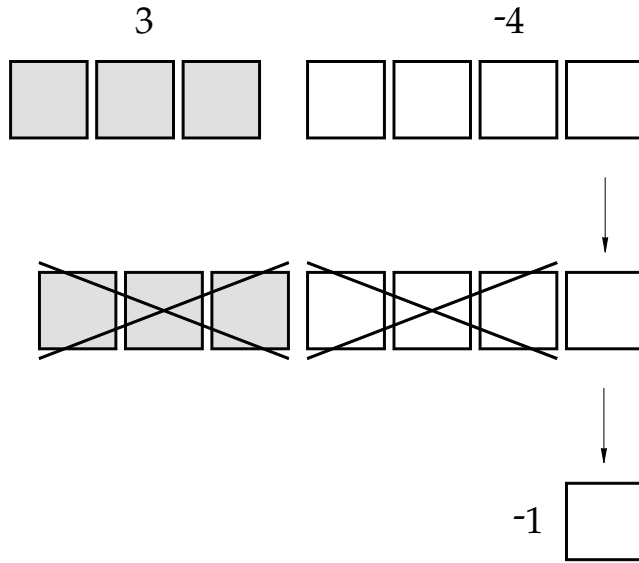

$$3 - 4 = -1$$

Here is another example:

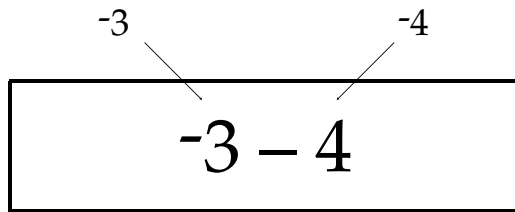

We think of the problem as starting with -3 and adding -4:

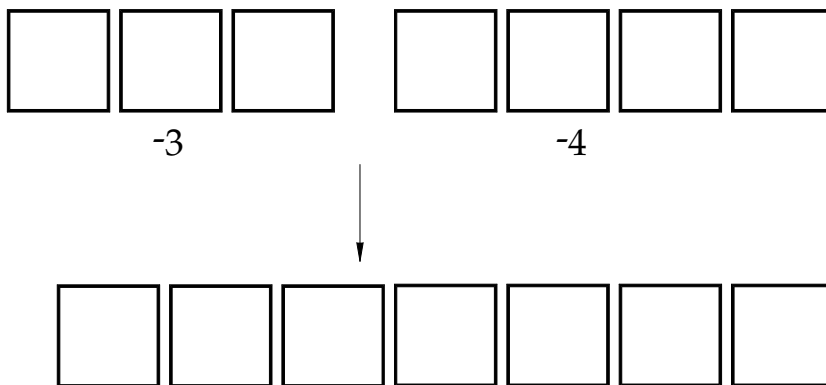

$$-3 - 4 = -7$$

The result is -7.

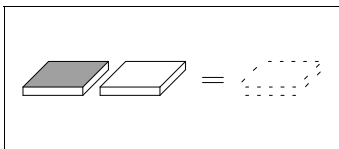

---

## Subtraction and Double Signs: Method I

---

If two signs appear next to each other with no number in between, think of them as double signs. Flip the chips for *each* negative or subtraction sign. If there are two negative signs, we flip the chips twice and the result is positive. We then add. For example:

$$\begin{array}{c} \boxed{3 - (-4)} \\ \begin{array}{cc} \swarrow & \searrow \\ 3 & -(-4) = +4 \end{array} \end{array}$$

This gives:

$$3 - (-4) = 3 + 4 = 7$$

---

## Summary: Method I

---

To add or subtract:

- Identify each number as positive or negative by the sign in front of it. Choose the correct color chips for each group, then add the groups together.
- If there are double signs in front of any number, flip that group of chips the proper number of times, then add the groups together.
- Think of all addition and subtraction as *addition*.

---

## Subtraction: Method II

---

We will now look at another way of subtracting. Method II is very much like Method I; you should use whatever method is most comfortable. It is best to understand both methods—they are simply two different ways to illustrate the same idea.

First, let's look at some examples of adding and subtracting where two different problems have the same answer:

$$4 - 3 = 1$$

$$4 + (-3) = 1$$

In the diagram below, you can see that *adding*  $-3$  is the same as *subtracting*  $3$ :a

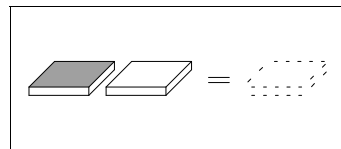

$$4 - 3 = 4 + (-3)$$

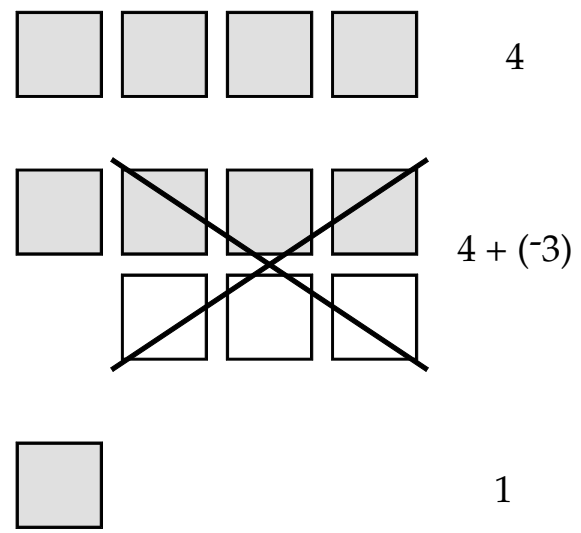
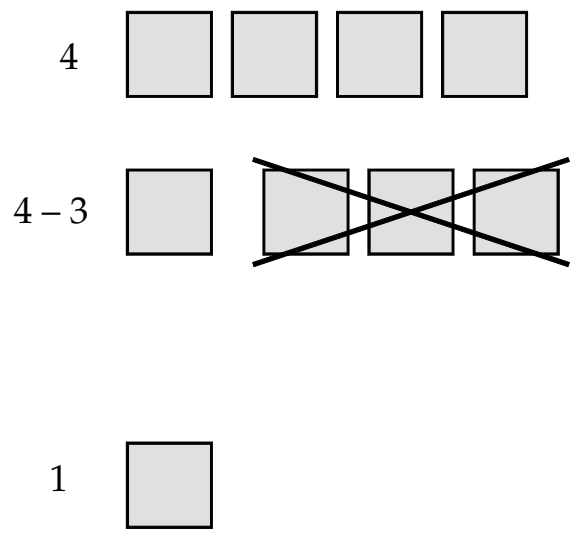

We can see that the following two examples also have the same result:

$$-4 - (-3) = -1$$

$$-4 + (+3) = -1$$

The diagram shows why this is true:

$$-4 - (-3) = -4 + (+3)$$

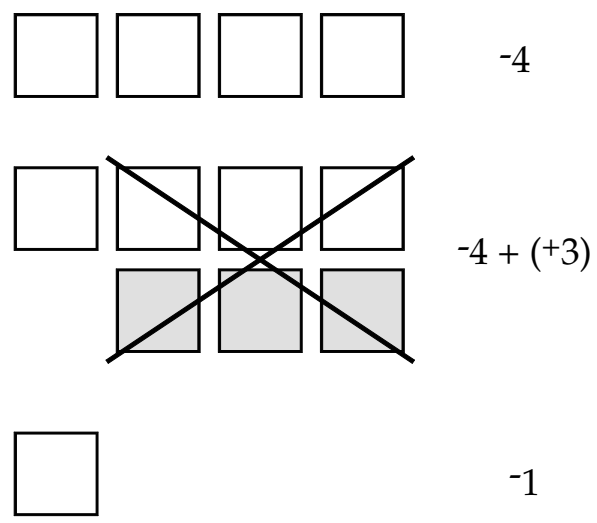
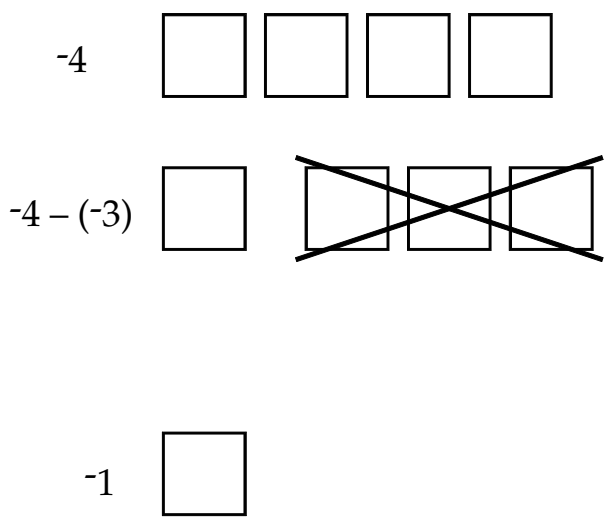

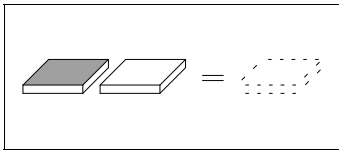

We can see that:

- Subtracting a positive number is the same as adding a negative number.
- Subtracting a negative number is the same as adding a positive number.
- In general, subtracting any number is the same as adding its opposite.

$$4 - 3 = 4 + (-3)$$

$$-4 - (-3) = -4 + (+3) = -4 + 3$$

Here are some examples of how to use Method II with subtraction:

$$7 - 2 = 7 + (-2) = 5$$

$$8 - (-3) = 8 + (3) = 11$$

$$-6 - 3 = -6 + (-3) = -9$$

With the chips, we set up a subtraction with Method II by taking out the two groups of chips indicated. We then flip the subtracted group of chips and combine the two groups. Here are three examples:

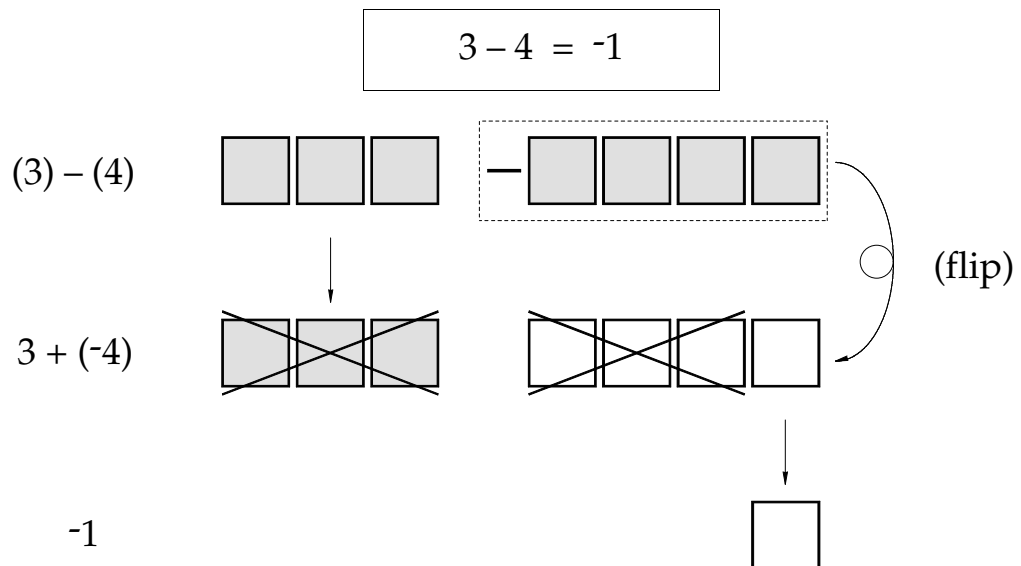



$$-3 - 4 = -7$$

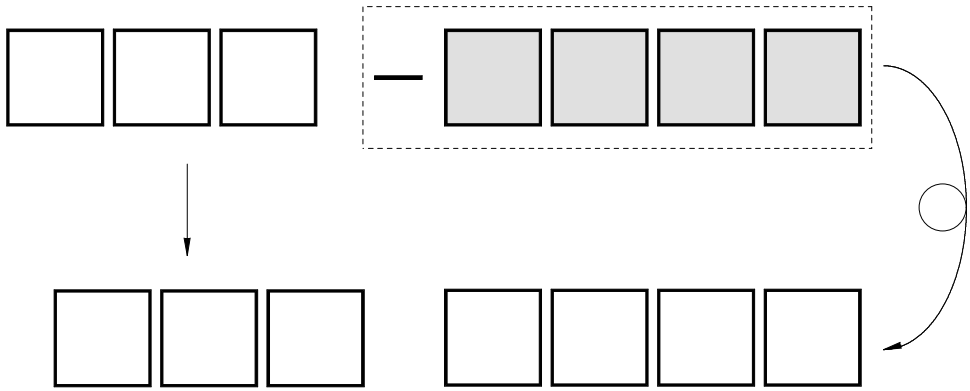
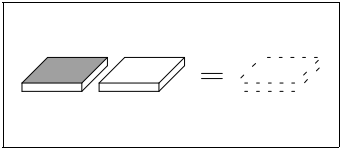

$$(-3) - (4)$$

$$(-3) + (-4) = -7$$

$$3 - (-4) = 7$$

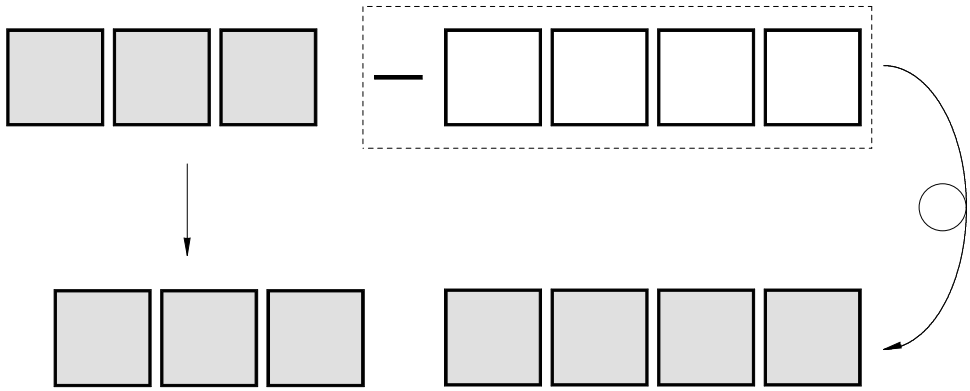

$$(3) - (-4)$$

$$(3) + (+4) = 7$$

---

**Summary: Method II**

---

To subtract ( $a$  and  $b$  stand for any numbers):

- $a - b = a + (-b)$
- $a - (-b) = a + (+b)$
- To subtract any number of chips, flip the subtracted chips and add.

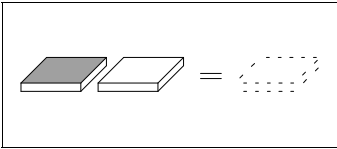

## Summary: Method I and Method II

We have looked at two methods for doing subtraction. With both methods, we think of subtraction as adding. With Method I, we just look at the signs in front of each number to see what color chips to add; with Method II, we look at every subtraction as adding the opposite.

### To Subtract:

**Method I: Choose the color of chips by looking at the signs in front of each number, then add.**

**Method II: Instead of subtracting the second number, flip the chips and add the opposite.**

## Exercises

Use the chips to do the following subtractions:

Example:  $7 - 4$

Solution: 3

(Method I)

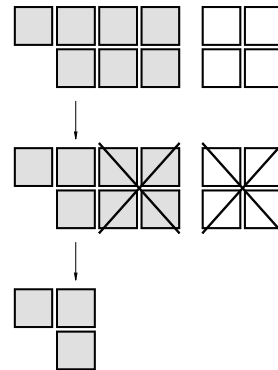

Example:  $(-7) - (-4)$

Solution: -3

(Method II)

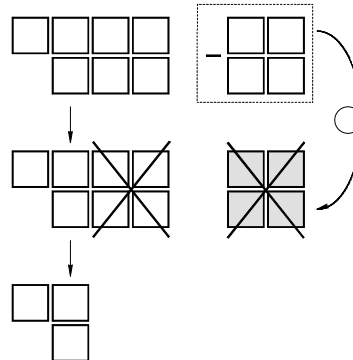

1.  $5 - (-3)$
2.  $-5 - (+3)$
3.  $-5 - (-3)$
4.  $-6 - (-3)$
5.  $3 - 5$
6.  $3 - (-5)$
7.  $-3 - 5$
8.  $-3 - (-5)$
9.  $0 - (-17)$
10.  $4 - 0$
11.  $6 - (-0)$
12.  $1 - (-1)$
13.  $12 - (-5)$
14.  $-12 - (-5)$
15.  $-7 - 9$
16.  $-7 - (-9)$
17.  $-4 - 4$
18.  $-4 - (-4)$
19.  $4 - (-4)$
20.  $-7 - 3$
21.  $-7 - (-3)$
22.  $7 - 3$
23.  $7 - (-3)$
24.  $5 - 2$
25.  $-5 - (-2)$
26.  $2 - 5$
27.  $-2 - (-5)$
28.  $-2 - 5$
29.  $2 - (-5)$
30.  $8 - (-4)$

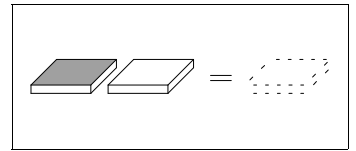

## Section 4

### Addition and Subtraction

#### Combining Addition and Subtraction

In a math sentence, if several signed numbers are written in a row with plus or minus signs in between the numbers, the sentence means that we should add the numbers by sliding the chips together and letting chips of different colors cancel out. The simplified answer is given by the sign and number of chips that are left when you're done. For example:

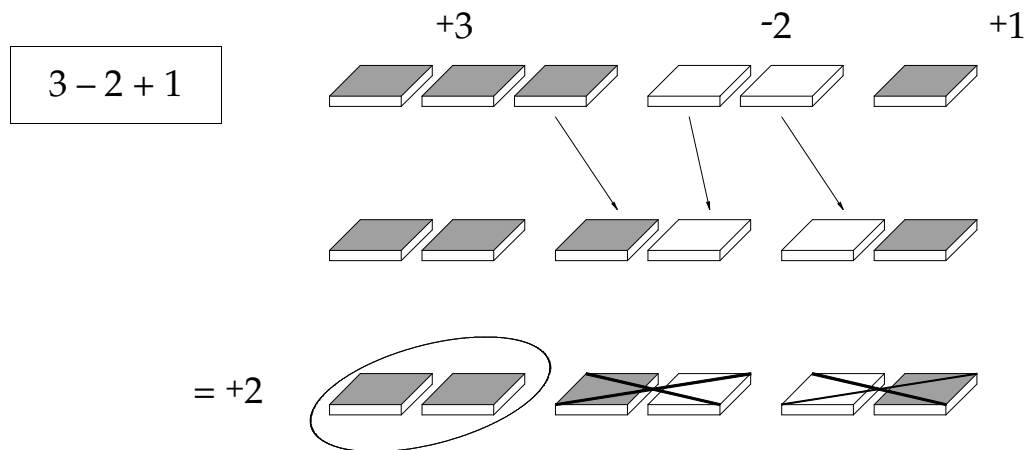

When you have three or more numbers together, we still think of them as being added. When subtraction is indicated, you may want to rewrite it as addition of the opposite kind of chips:

$$3 - 2 + 1 = 3 + (-2) + 1$$

Then combine the chips to get the result. You can combine them in order from left to right:

$$\begin{array}{c}
 3 + (-2) + 1 \\
 \diagdown \quad \diagup \quad \diagdown \quad \diagup \\
 1 \quad + \quad 1 \\
 \diagdown \quad \diagup \\
 2
 \end{array}$$

Or you can rearrange the chips to add up the positives and negatives separately, and then cancel:

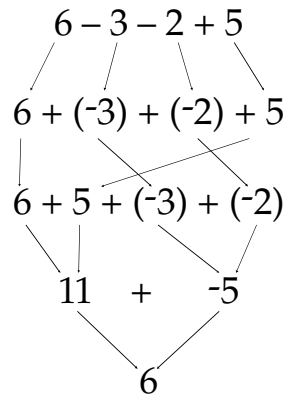
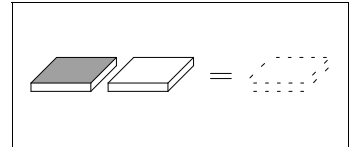

---

## Summary

---

When we have to add and subtract more than 2 numbers in a row, we use either method from the previous section and we consider all addition and subtraction as combining groups of chips:

- **Combine the numbers in pairs**
- **Or, rearrange all of the positive numbers in one group and the negative numbers in another. Find the total negatives and total positives, then combine the totals.**

---

## Exercises

---

Use the chips to find the answer and to illustrate the following problems:

Example:  $-5 + 2 - 3 = -6$

Solution:

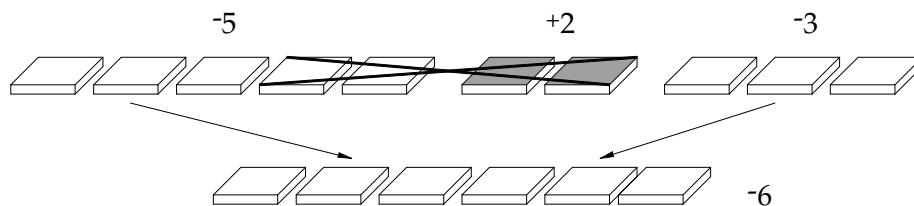

1.  $+1 - 4 + 3 = 0$
2.  $-2 + 1 - 4 =$
3.  $+2 + 3 - 1 - 2 =$
4.  $+5 - 6 - 3 - 1 =$

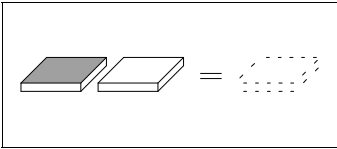

5.  $+2 - 7 + 5 - 1 =$

6.  $+6 + 4 + 3 + 3 =$

7.  $-1 + 5 - 6 + 2 =$

Use chips to show the following:

8.  $+(-3) = -3$

9.  $-(-2) = +2$

10.  $+(+5) = +5$

Use chips to do the following problems:

Example:  $-3 + (-2) = -5$

Solution:

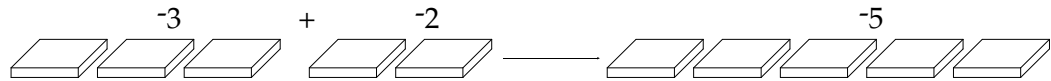

11.  $-2 - -2 = 0$

12.  $+2 - -2 = +4$

13.  $-1 - -5 = +4$

14.  $-(-2) + 3 =$

15.  $+(+5) - (-2) =$

16.  $-(+2) + 6 =$

17.  $-3 - -7 =$

18.  $-3 + 5 =$

19.  $3 + -5 =$

20.  $-3 + -5 =$

21.  $3 - -5 =$

22.  $-6 - 2 =$

23.  $-7 - -3 =$

24.  $-7 - 3 =$

25.  $7 - 3 =$

26.  $7 - -3 =$

27.  $-8 + -6 =$

---

## Section 5

### Multiplication

---

#### The Meaning of Multiplication

---

To multiply the numbers 3 and 2 using chips, make a rectangle 3 chips long and 2 chips wide, using six chips in all. We use a raised dot to indicate multiplication:

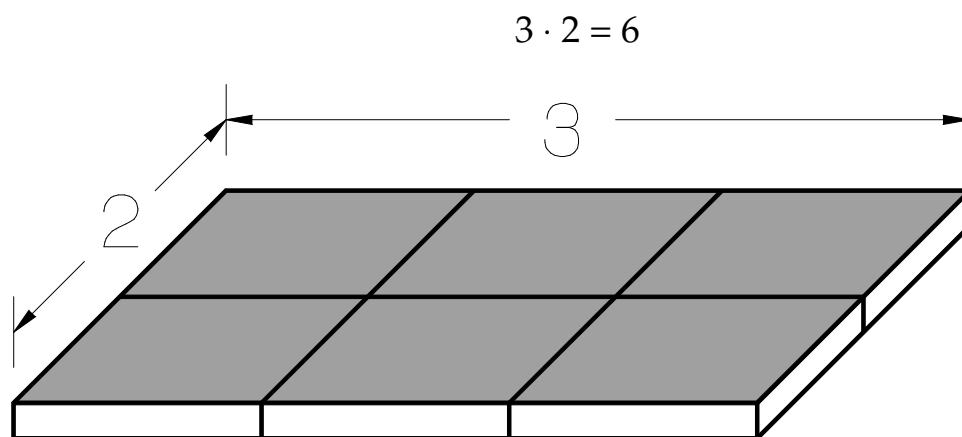

This shows either 3 groups of 2, or 2 groups of 3.

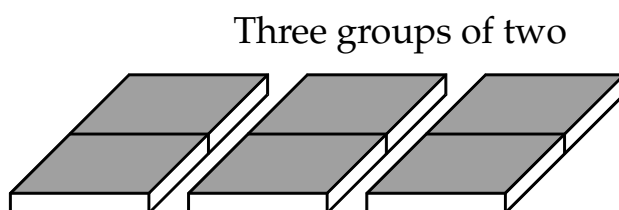
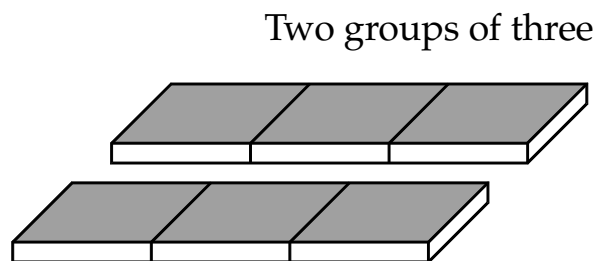

Multiplying any two numbers using chips means making a rectangle of chips with the numbers being the length and width. *Multiplying is making rectangles.* The answer to the multiplication—the product—is the total number of chips in the rectangle.

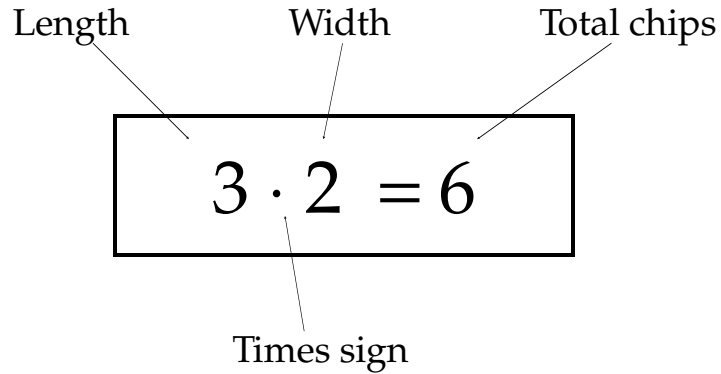
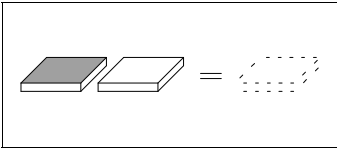

---

### Multiplying with Signed Numbers

---

When multiplying signed numbers using chips we will still make a rectangle of chips, but we flip the chips once for each negative (-) sign used in the multiplication. Remember that we start with colored side up.

$$(+3) \cdot (+2) = 6$$

(No Flips)

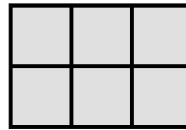

$$(+3) \cdot (-2) = -6$$

(One Flip)

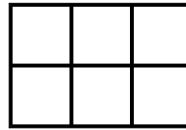

$$(-3) \cdot (+2) = -6$$

(One Flip)

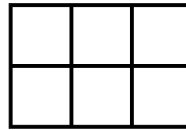

$$(-3) \cdot (-2) = +6$$

(Two Flips)

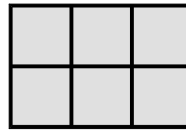

Here are some more examples:

$$9 \cdot (-8) = -72 \quad (1 \text{ flip})$$

$$-6 \cdot 3 = -18 \quad (1 \text{ flip})$$

$$(-6) \cdot (-3) = 18 \quad (2 \text{ flips})$$



Here is how to use the chips for multiplying signed numbers:

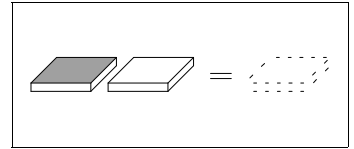

$$5 \cdot (-3) = -15$$

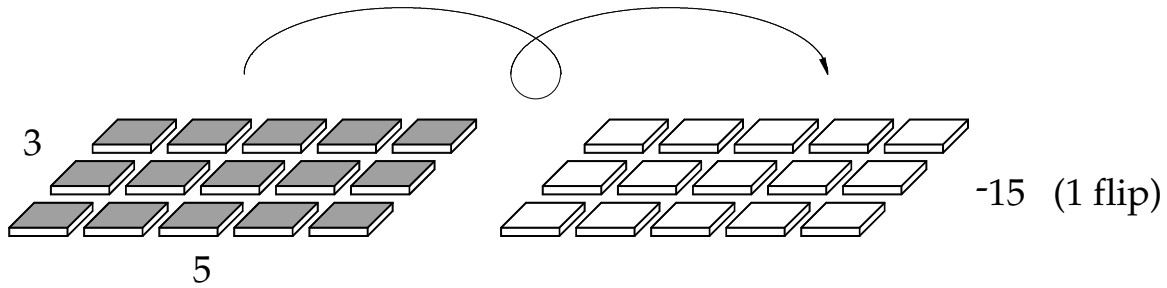

$$-4 \cdot 3 = -12$$

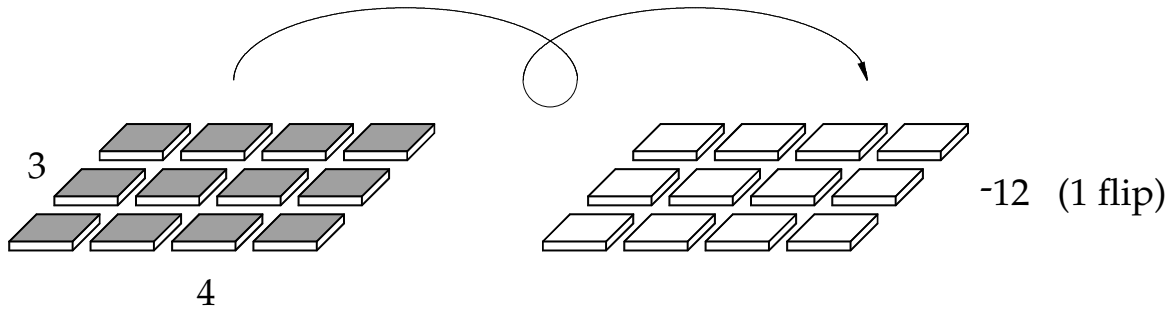

$$(-3) \cdot (-5) = +15$$

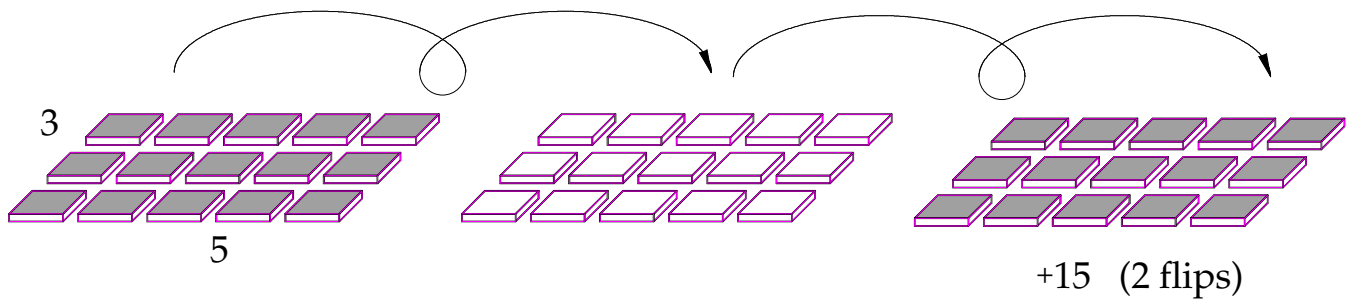

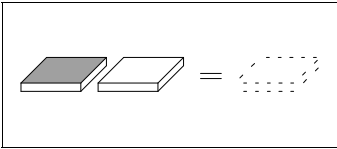

We can now state the procedure for multiplying:

### Multiplication of Two Numbers:

**Make a rectangle with one number as the length and the other as the width.**

**Flip all the chips once for each negative sign.**

**The area and the color give the result.**

We can see that there is an obvious method for finding the sign of the answer in a multiplication problem:

### The Sign of the Result:

**If one side of the rectangle is negative and the other side is positive, the rectangle is *negative*.**

**If both sides of the rectangle are positive, or both sides are negative, then the rectangle is positive.**

## Exercises

---

Use chips to perform the following multiplications:

Example:  $(-3) \cdot (-4) = +12$

Solution:

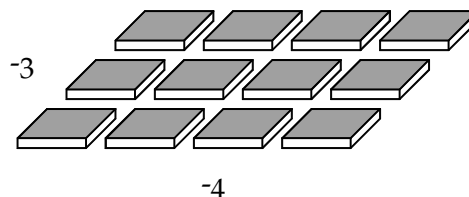

1.  $(-3) \cdot (+3) = -9$
2.  $(-2) \cdot (-5) = +10$
3.  $(-2) \cdot (+5) =$
4.  $(+5) \cdot (+3) =$
5.  $(-4) \cdot (-3) =$
6.  $(+3) \cdot (-1) =$
7.  $(-2) \cdot (-2) =$
8.  $(-2) \cdot (+2) =$
9.  $4 \cdot 7 =$
10.  $(-4) \cdot (-7) =$
11.  $(-4) \cdot 7 =$
12.  $1 \cdot 1 =$
13.  $1 \cdot (-1) =$
14.  $(-1) \cdot (-1) =$
15.  $(1) \cdot (17) =$
16.  $(-1) \cdot (17) =$
17.  $(0) \cdot (-17) =$
18.  $(-5) \cdot (-6) =$
19.  $-3 \cdot (2) =$
20.  $(-5) \cdot (-3) =$
21.  $-4 \cdot 3 =$
22.  $2 \cdot (-7) =$
23.  $-2 \cdot (7) =$
24.  $-2 \cdot (-7) =$
25.  $(6) \cdot (-3) =$
26.  $(-6) \cdot (3) =$
27.  $(-6) \cdot (-3) =$
28.  $-1 \cdot (-12) =$
29.  $-3 \cdot (-3) =$
30.  $-5 \cdot (+5) =$

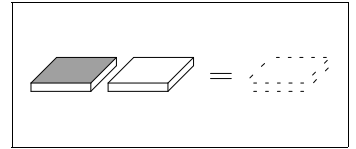

# Section 6

## Division

---

### The Meaning of Division

---

Division is often described as backwards multiplication. For example, if we want to know:

$$12 \div 4 = ?$$

We usually think of this as:

“How many fours are in 12?”

Using chips, this is also the opposite of multiplication. Since multiplication is making rectangles and counting the result, division also involves rectangles. The problem above becomes:

“Take 12 unit chips and form a rectangle with side 4.

What is the other side?”

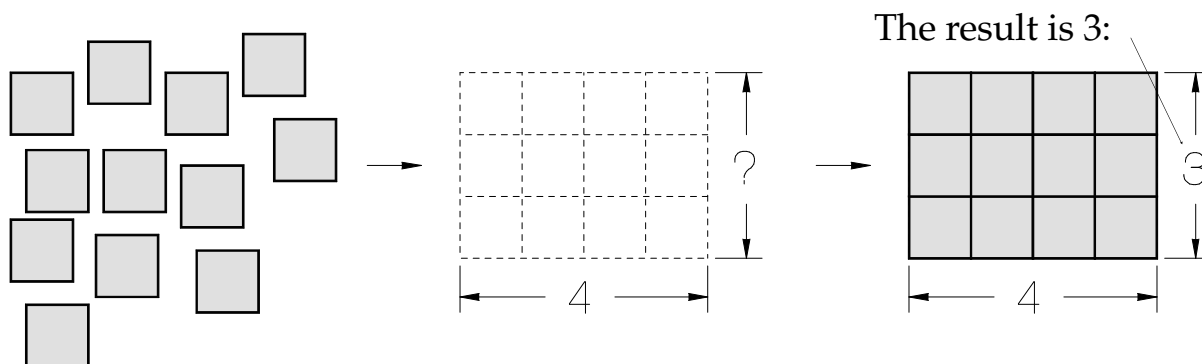
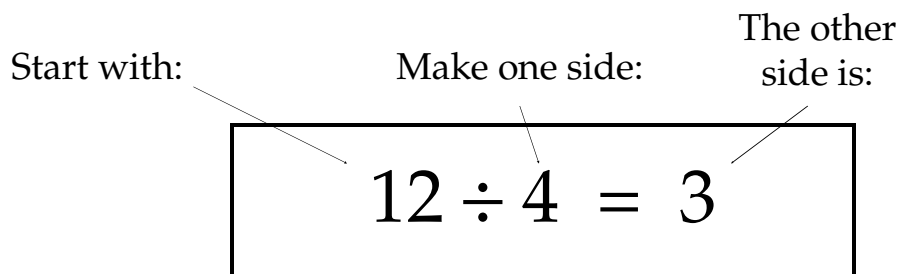

## Division with Signed Numbers

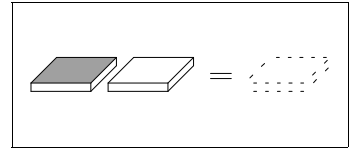

If we have a division problem with one or two negative numbers, we continue to think backwards:

$$-12 \div 4 = ?$$

becomes

“What times 4 is equal to -12?”

The answer is -3 because -3 times 4 is -12. To do this with chips, we start with -12 unit chips and build a rectangle that is 4 on one side. The other side is 3 units. Because the answer needs to be -12, we can see that the chips have been flipped once, so the answer—the missing side—must be negative.

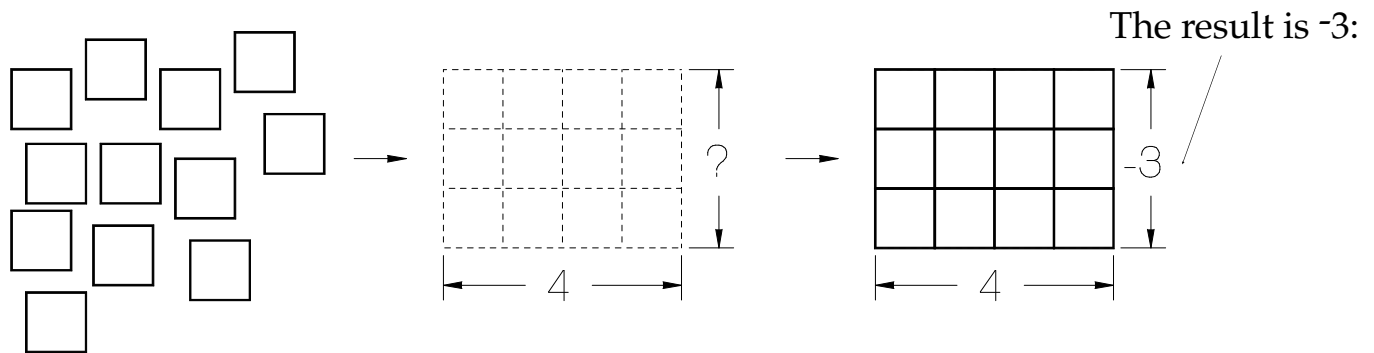

We can do other division problems in the same way. For example, what is:

$$12 \div (-4)?$$

We start with 12 chips and build a rectangle with one side of -4. The given side (-4) is negative and accounts for one flip. To get back to an area of +12, we need another flip, so the other side must be negative. The answer is -3.

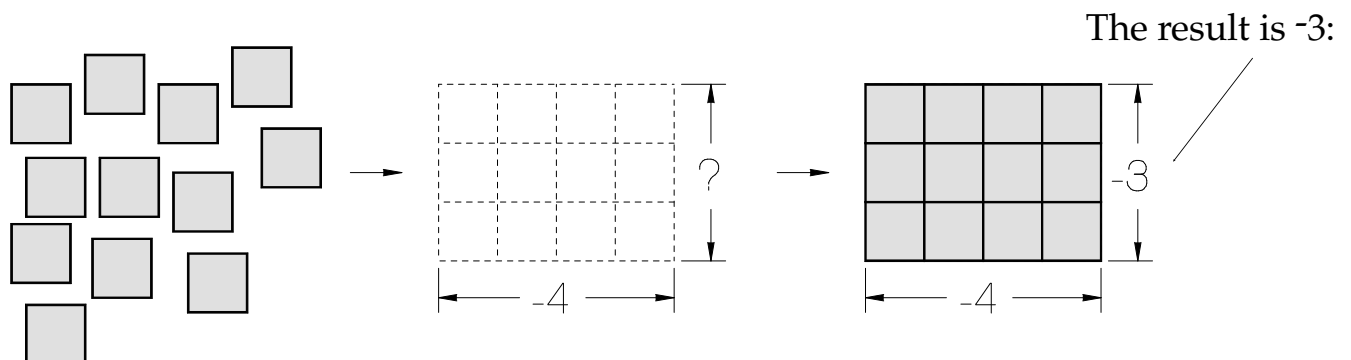

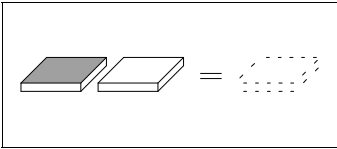

Finally, how would we illustrate:

$$-12 \div (-4)?$$

As we did above, we start with -12 chips and a side of -4 and then we can see that the other side is 3. We flip the chips once for -4, giving the negative sign that -12 requires, so the other side is positive 3.

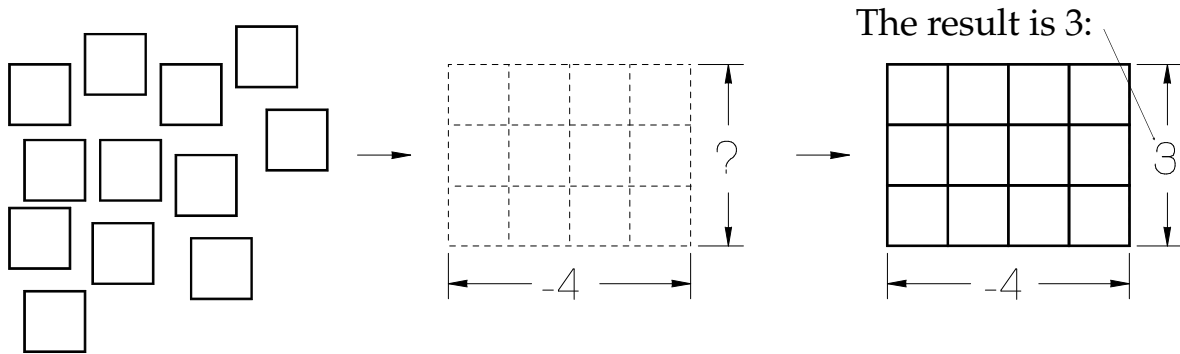

Division problems in algebra are most often written as fractions; instead of writing

$$12 \div 4 = 3$$

we will commonly write

$$\frac{12}{4} = 3$$

You are probably aware that we can think of fractions as division problems and we can rewrite division problems as fractions. When writing division problems as fractions, we normally will reduce all fractions and we will write "improper" fractions as mixed numbers.

*For an explanation of why a division problem can be rewritten as a fraction, please see Section 3 (Compound Fractions) of the FRACTIONS chapter.*

---

## Summary

---

Division is the opposite of multiplication. Since multiplication is making rectangles, division is making rectangles in reverse:

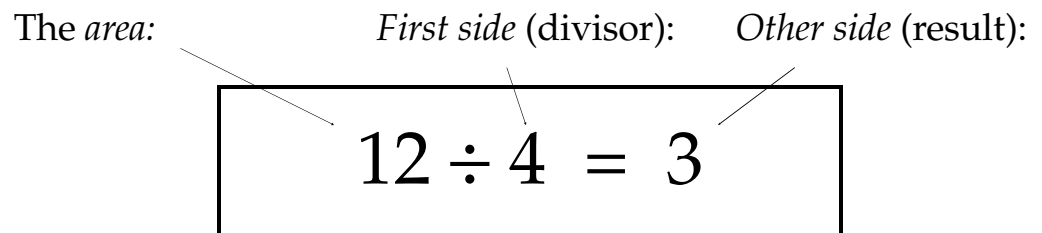

### Division:

1. Start with unit chips (the *area*).
2. Build a rectangle with the divisor for the *first side*.
3. How long is the *other side*?
4. The color of the *area* and the sign of the *first side* will tell you the sign needed for the *other side* (*result*).

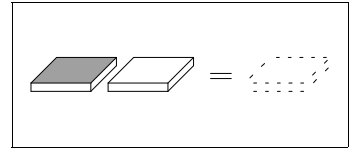

### Division: The Sign of the Result

1. If the area is positive:  
Both sides are positive,  
or both sides are negative.
2. If the area is negative:  
One side is negative,  
and the other side is positive.

Positive divided by Positive is Positive

Positive divided by Negative is Negative

Negative divided by Positive is Negative

Negative divided by Negative is Positive

### Exercises

---

Complete the following division problems using the chips:

1.  $12 \div (-2)$
2.  $-12 \div (+2)$

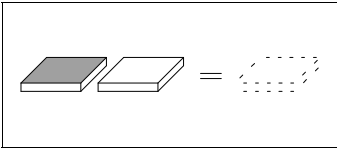

3.  $-12 \div (-2)$
4.  $16 \div (-8)$
5.  $-16 \div (-4)$
6.  $4 \div (4)$
7.  $4 \div (-4)$
8.  $-4 \div (4)$
9.  $1 \div (-1)$
10.  $-1 \div (-1)$
11.  $0 \div 17$
12.  $0 \div (-17)$
13.  $14 \div (-7)$
14.  $-16 \div (-2)$
15.  $18 \div (-3)$
16.  $-22 \div (-11)$
17.  $20 \div (-5)$
18.  $-20 \div 5$
19.  $-20 \div -5$
20.  $-5 \div (-5)$
21.  $\frac{12}{-3}$
22.  $\frac{15}{5}$
23.  $\frac{-14}{7}$
24.  $\frac{-8}{-2}$
25.  $\frac{-20}{4}$
26.  $\frac{-20}{-4}$
27.  $\frac{-24}{9}$
28.  $\frac{-24}{-9}$
29.  $\frac{9}{6}$
30.  $\frac{-12}{5}$



---

## Section 7

### The Number Line

---

#### Numbers as Distance

---

A number line is a useful method of representing positive and negative numbers and their relationships. A number line is similar to a measuring tape; distances from the end of the tape (zero) are marked out in equal divisions along the tape. (Most measuring tapes use units of inches or centimeters.)



The farther you move along the tape the higher the numbers get. Between the whole numbers units are parts of units, marked off in fractions or decimals.

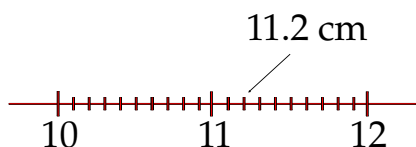
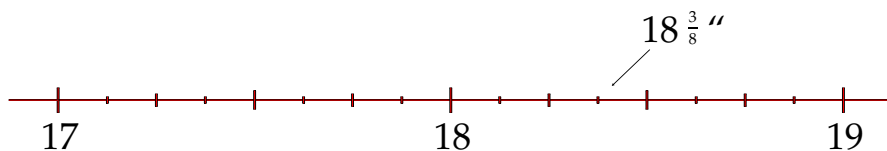

Even between the closest marks on the measuring tape, we know that *any* small fraction or decimal part of a unit could be represented if we used a magnifying glass or a micrometer. In these ways a number line is again just like a measuring tape.

A number line is different from a tape measure in that the number line marks off both *positive* and *negative* distances from zero by defining one direction as positive and the opposite direction as negative, with zero in the middle.

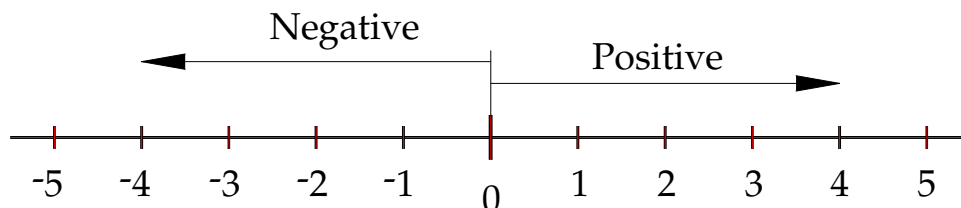

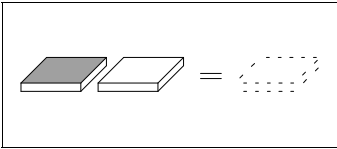

Generally, distances to the right of zero along the number line are called positive, and distances to the left of zero are called negative. Notice from the picture that the large, more positive numbers lie farther to the right, and the more negative numbers lie farther to the left. Since negative numbers are like being *below zero* or *in the hole*, we say that any number on the number line is greater than (more positive than) any number lying to its left.

8 is greater than (more positive than) 3.

-2 is greater than (more positive than) -5.

A number line also differs from a measuring tape because the units on the number line don't actually represent distances like inches or centimeters. The number line is made up of what are called **pure numbers**, which don't necessarily represent any lengths or objects, but are just numerical values.

Of course numerical values might be used to represent numbers of objects, etc., but these representations are not necessary to use a number line.

---

### Adding on a Number Line

---

Positive numbers are represented on a number line as arrows pointing to the right and having a length showing the number of units.

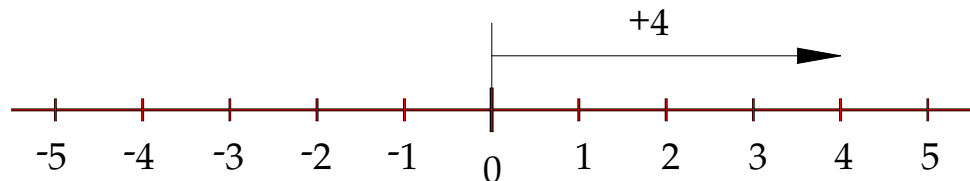

Negative numbers are represented as arrows pointing to the left and also having length equaling the number of units.

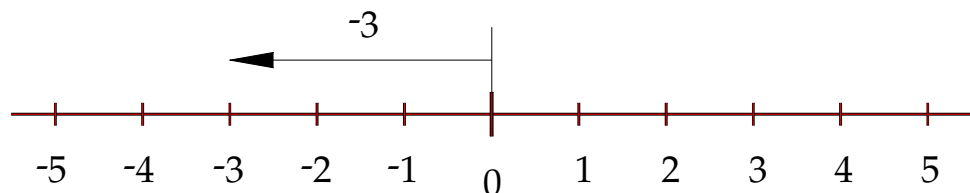

To add several numbers on the number line we represent each number as an arrow. Beginning with the tail of the first arrow at zero, we place the tail of each succeeding arrow at the tip-point of the previous arrow. The sum of the numbers is the position on the number line of the tip of the final arrow.

For example:

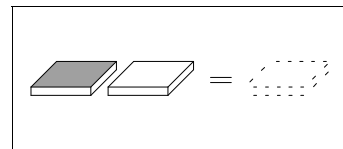
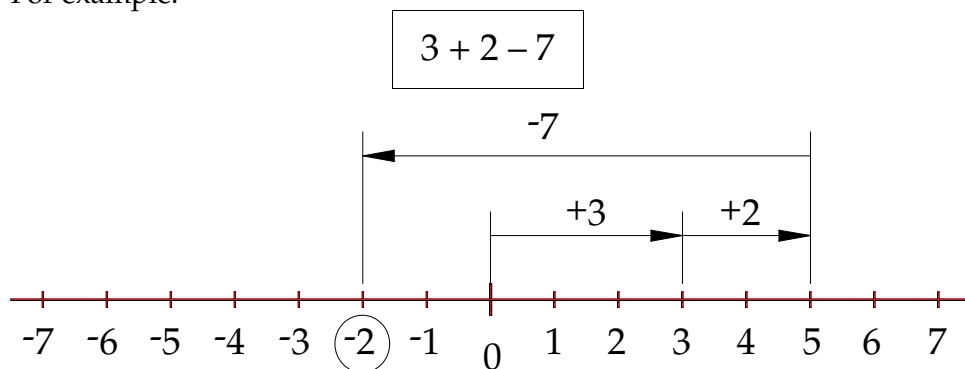

The sum is -2. Another example:

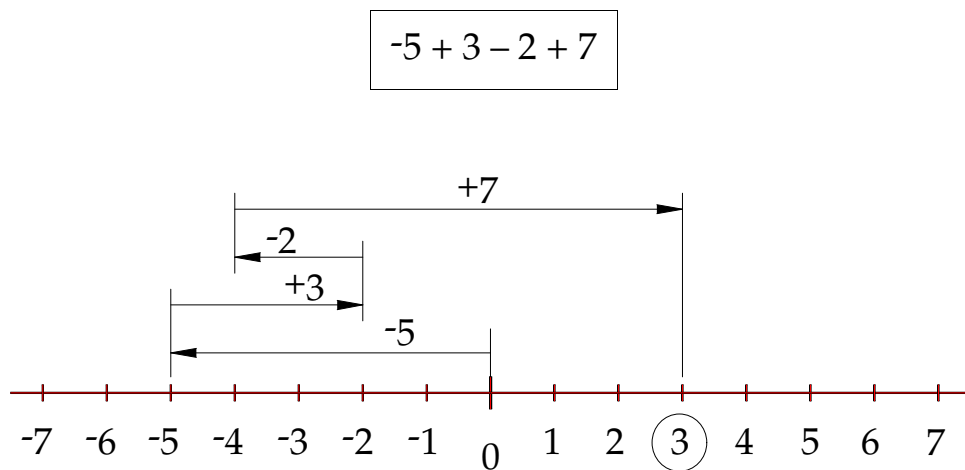

The sum is +3.

Before adding on a number line, you must simplify all double negatives to positives. The answers we get from adding on a number line will always be exactly the same as the answers we get by adding positive and negative chips; only the representation is different.

## Exercises

---

Draw number lines and arrows to complete these additions. Circle the resulting sum. (Remember, the spaces between the units on the number line must all be the same.)

1.  $3 + 5 - 2$
2.  $-2 + 4 - 6$
3.  $-3 - 2 + 4$
4.  $2 - (-5) - 3$

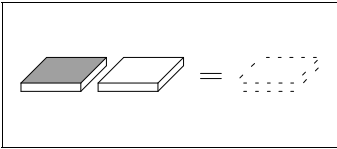

Make a number line and complete the following additions by counting with your pencil point. Start with your pencil point at zero, and count steps to the right for each positive number and steps to the left for each negative number added. Get your result from the number line without drawing arrows.

5.  $2 - 5 + 3 - 1$
6.  $-3 - 5 + 2 + 1$
7.  $7 + 1 - 5 - 3$
8.  $-2 + 5 - 6 + 1$
9.  $4 + 3 - (-2) + (-5)$
10.  $-5 - (-3) + (-2) - 4$

For discussion:

11. If a tape measure is going to work, why must the separation of all the units be the same?
12. How would you multiply using a number line?